

Standard rivet gun nozzles do not fit inside cleat.

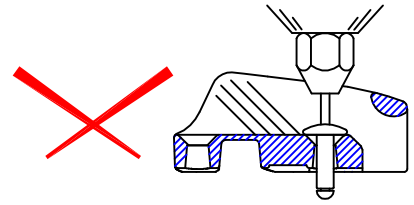

Use 2 or 3 nuts to extend nozzle.

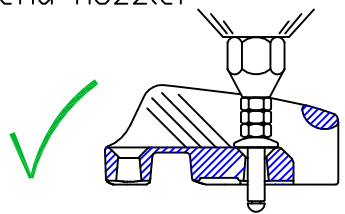

Extended nozzle is best Consult rivet gun supplier.

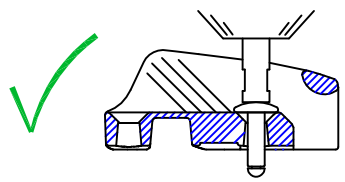

2 Holes 3.5dia
Countersunk 7.5dia x 90deg

Section A-A

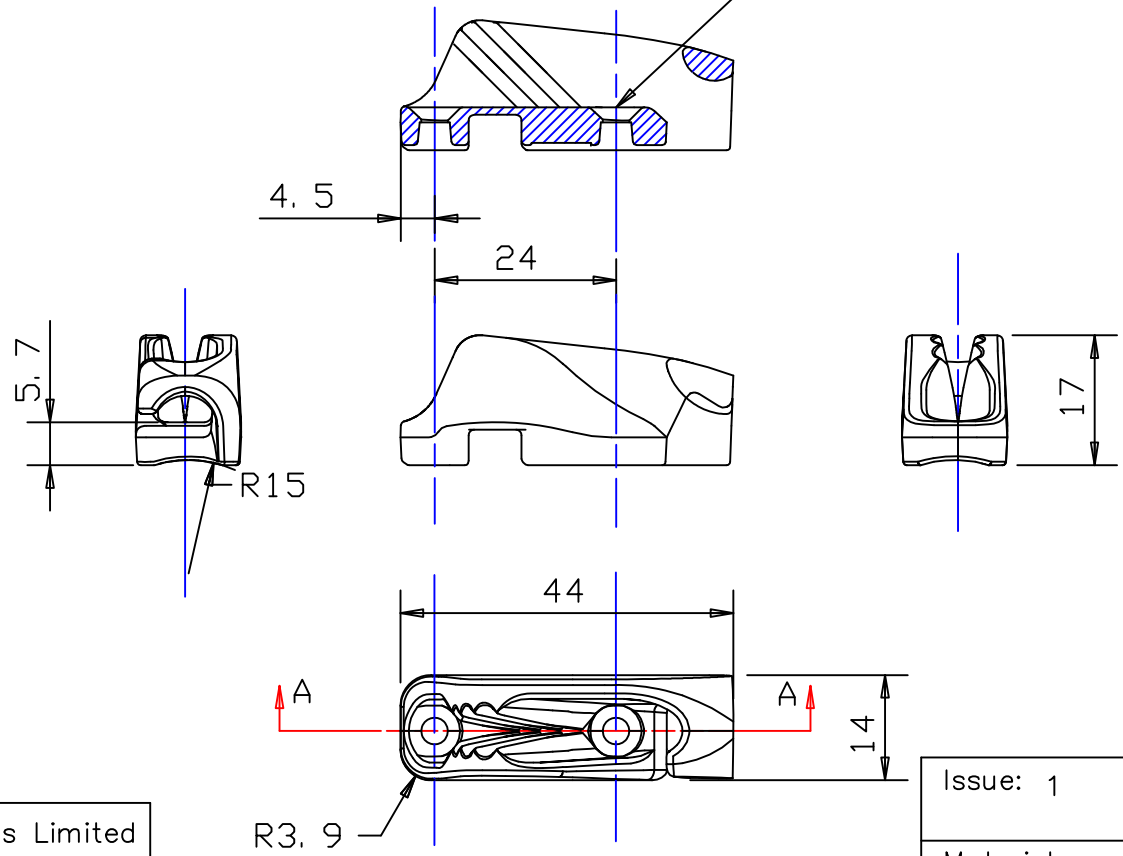

Clamcleat®
Rope cleats

Clamcleats Limited
Watchmead
Welwyn Garden City
Hertfordshire AL7 1AP
England
Telephone +44 (0)1707 330101
Fax +44 (0)1707 321269
Email sales@clamcleat.com
www.clamcleat.com

Scale 1:1
All dimensions in mm.

Issue: 1	Dec 2008
ID277.dwg	
Material: Diecast Aluminium	
Installation Drawing for: -	
CL277	
Racing Micros	